

FULLY WELDED TRUNNION & EXTENDED STEM BALL VALVE

DESIGN FEATURES

Transition Pups

- Transition pups are supplied on request for welded end valves

Extended Stem

- Valves installed underground or in remote loactions can be operated with an optional extended stem.
- All the drain, vent and emergency sealant connections can be operated using extended connecting pipes firmly attached to the stem protective cover.

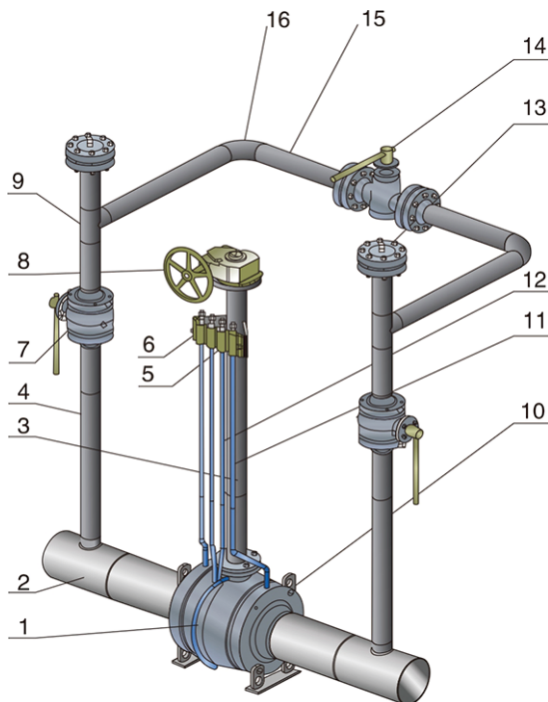

COMPLETE BY-PASS SYSTEM

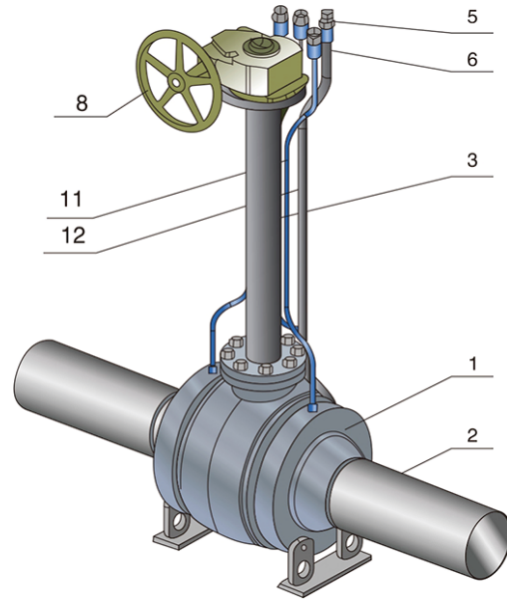

EXTENDED STEM BALL VALVE

Design Feture:

- Full Welded Body and End
- Full Bore
- Trunnion Mounted Ball
- Low Torque
- Under Ground
- Stem and Seat Sealant Injection
- Fire Safely Design
- Anti-blow Out Stem

NO.	PART NAME	SAMPLE MATERIALS	NO.	PART NAME	SAMPLE MATERIALS
1	VALVE	ASTM A105	9	TEE	CARBON STEEL
2	PUPS	API 5L GR.B	10	LIFT LUG	CARBON STEEL
3	EXTEND PIPE	CARBON STEEL	11	LUBRICANT PIPE	ASTM A106
4	BLOW PIPE	ASTM A106	12	DRAIN PIPE	ASTM A106
5	DRAIN VALVE	CARBON STEEL	13	BLIND FLANGE	ASTM A105
6	LUBRICANT FITTING	CARBON STEEL	14	BY-PASS VALVE	ASTM A105
7	CONNECTION VALVE	ASTM A105	15	BY-PASS PIPE	ASTM A106
8	GEAR	ASSEMBLY	16	ELBOW	CARBON STEEL

The material is according to ASTM Standard.

Model Denote:EFC=Elite Flow Control | 02=Size in inch | BV=Ball Valve | 1=150Lb | B=BW End | 4=Trunnion, Welded Body.