

MODEL NO.:EFC-1/2GE1
Size:3/8" ~ 2" (DN10 ~ DN50)

API 602 FORGED STEEL GLOBE VALVE

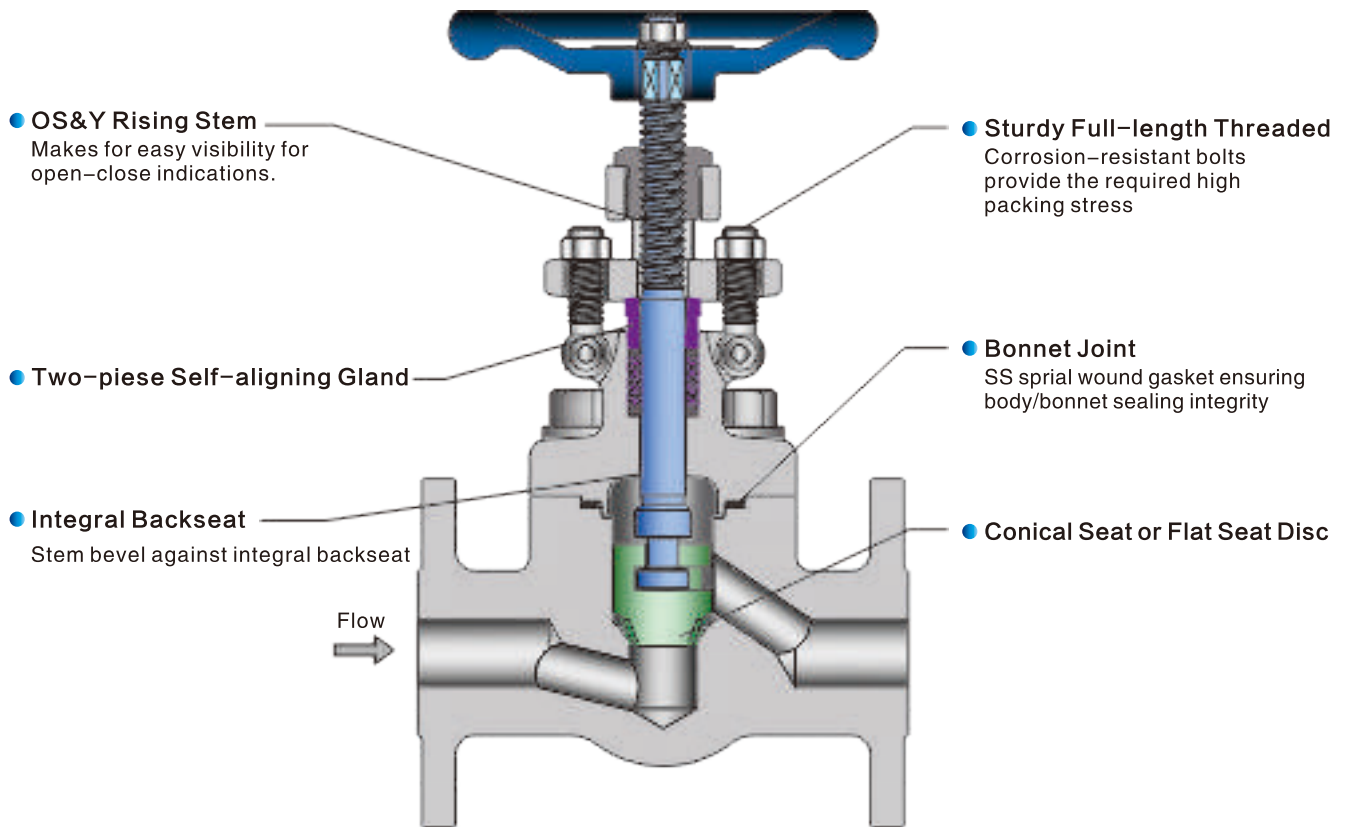

SPECIFICATION			
Design & MFG.	API 602	End Threads	ASME B1.20.1
Press-Temp Rat.	ASME B16.34	Socket-Weld	ASME B16.11
End Flange	ASME B16.5	Test	API 598

OPTIONAL DESIGN FEATURES

1. Live-loading

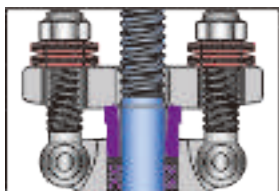

2. Welded Bonnet

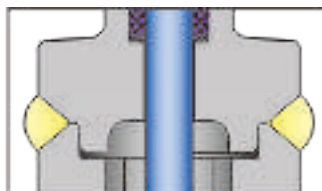

3. Grease injector & lantern ring

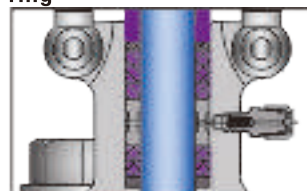

4. Integrally Extended Body ring

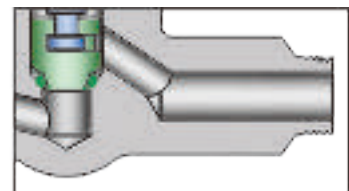

The material is according to ASTM Standard
 Model Denote: EFC=Elite Flow Control | 1/2=Size in inch | GE=Globe Valve | 1=150Lb

MODEL NO.:EFC-1/2GE1
Size:3/8" ~ 2"(DN10 ~ DN50)



API 602 FORGED STEEL GLOBE VALVE

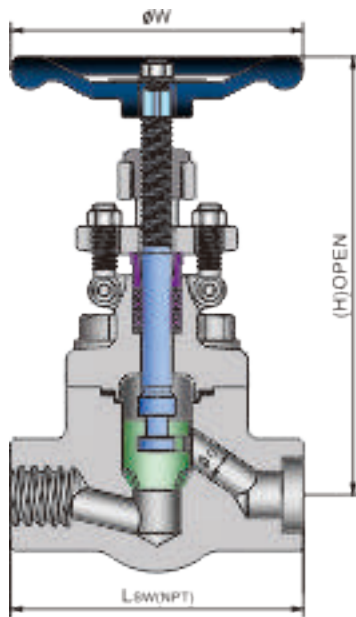

SW(NPT) BOLTED BONNET
800,1500LB

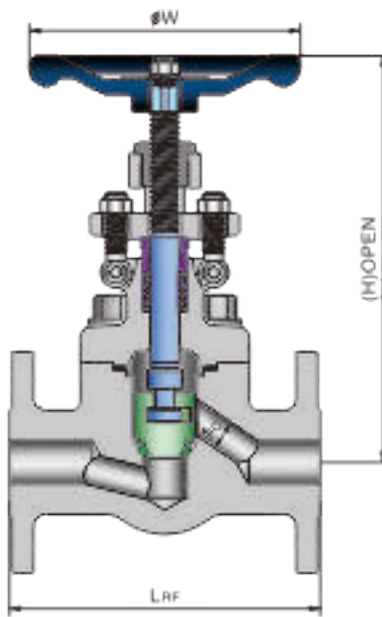

FLANGED BOLTED BONNET
150~1500LB

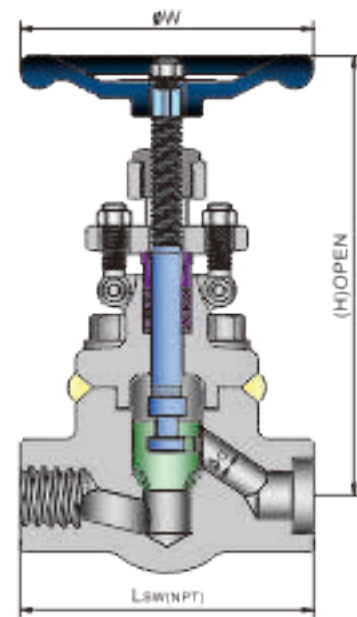

SW(NPT) WELDED BONNET
800,1500LB

Material List

PART	STANDARD MATERIALS					
BODY	ASTM A105+STL	ASTM A350 LF2+STL	ASTM A182 F304(L)	ASTM A182 F316(L)	ASTM A182 F51/F53	ASTM A182 F11+STL
DISC	ASTM A182 F6a	ASTM A182 F6a	ASTM A182 F304(L)	ASTM A182 F316(L)	ASTM A182 F51/F53	ASTM A182 F6a
STEM	ASTM A182 F6a	ASTM A182 F6a	ASTM A182 F304(L)	ASTM A182 F316(L)	ASTM A182 F51/F53	ASTM A182 F6a
GASKET	SS+FLEXIBLE GRAPHITE					
BONNET	ASTM A105	ASTM A350 LF2	ASTM A182 F304(L)	ASTM A182 F316(L)	ASTM A182 F51/F53	ASTM A182 F11
BOLT	ASTM A193 B7	ASTM A320 L7	ASTM A193 B8(M)	ASTM A193 B8(M)	ASTM A193 B8M	ASTM A193 B16
PACKING	FLEXIBLE GRAPHITE					
GLAND	ASTM A276 410	ASTM A276 410	ASTM A276 304	ASTM A276 316	ASTM A276 316	ASTM A276 410
GLAND FLANGE	ASTM A105	ASTM A350 LF2	ASTM A182 F304	ASTM A182 F304	ASTM A182 F304	ASTM A105
EYEBOLT	ASTM A193 B7	ASTM A320 L7	ASTM A193 B8(M)	ASTM A193 B8(M)	ASTM A193 B8M	ASTM A193 B16
NUT	ASTM A194 2H	ASTM A194 7	ASTM A194 8(M)	ASTM A194 8(M)	ASTM A194 8M	ASTM A194 4
STEM NUT	ASTM A276 420	ASTM A276 420	ASTM A276 420	ASTM A276 420	ASTM A276 420	ASTM A276 420
HANDWHEEL	ASTM A197					
NAME PLATE	SS304					

The material is according to ASTM Standard

Model Denote:EFC=Elite Flow Control | 1/2=Size in inch | GE=Globe Valve | 1=150Lb

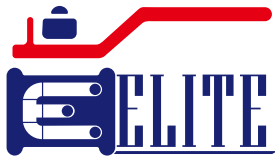

MODEL NO.:EFC-1/2GE1
Size:3/8" ~ 2" (DN10 ~ DN50)

API 602 FORGED STEEL GLOBE VALVE

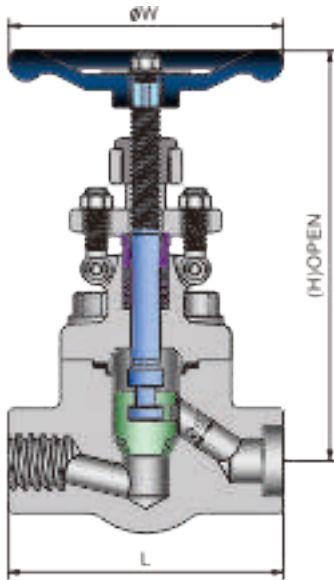

800LB SW(NPT), Bolted Bonnet or Welded Bonnet

Nominal Diameter	Standard Port	mm(in)	15(1/2)	20(3/4)	25(1)	32(1 1/4)	40(1 1/2)	50(2)	65(2 1/2)
	Full Port	mm(in)	10(3/8)	15(1/2)	20(3/4)	25(1)	32(1 1/4)	40(1 1/2)	50(2)
ϕd (Flow Passway)		mm	10	13	18	23	28	36	44
Lsw(NPT)(Face to Face)		mm	79	92	111	120	152	172	220
H(Open Height)		mm	166	170	206	230	246	283	330
ϕW (Handwheel)		mm	100	100	125	160	160	180	220
WEIGHT		kg	1.9	2.1	3.3	5.2	7.5	11.4	14.4

1500LB SW(NPT), Bolted Bonnet or Welded Bonnet

Nominal Diameter	Standard Port	mm(in)	15(1/2)	20(3/4)	25(1)	32(1 1/4)	40(1 1/2)	50(2)
	Full Port	mm(in)	10(3/8)	15(1/2)	20(3/4)	25(1)	32(1 1/4)	40(1 1/2)
ϕd (Flow Passway)		mm	10	13	18	23	28	33
Lsw(NPT)(Face to Face)		mm	92	111	120	152	172	220
H(Open Height)		mm	170	206	230	246	283	330
ϕW (Handwheel)		mm	100	125	160	160	180	220
WEIGHT		kg	2.2	3.8	5.8	8.6	12.7	16.4

150~600LB RF, Standard port, Bolted Bonnet or Welded Bonnet

Nominal Diameter	mm(in)	15(1/2)	20(3/4)	25(1)	32(1 1/4)	40(1 1/2)	50(2)	
ϕd (Flow Passway)		mm	10	13	18	23	28	36
L_{RF} (Face to Face)	150LB	mm	108	117	127	140	165	203
	300LB	mm	152	178	203	216	229	267
	600LB	mm	165	190	216	229	241	292
H(Open Height)	150 ~ 600LB	mm	166	170	206	230	246	283
ϕW (Handwheel)		mm	100	100	125	160	160	180

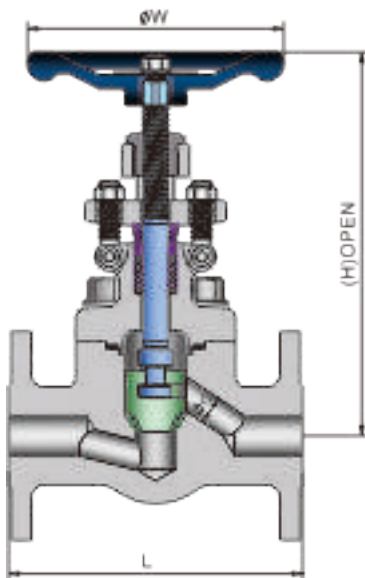

900~1500LB RTJ, Standard port, Bolted Bonnet or Welded Bonnet

Nominal Diameter	mm(in)	15(1/2)	20(3/4)	25(1)	32(1 1/4)	40(1 1/2)	50(2)	
ϕd (Flow Passway)		mm	10	13	18	23	28	33
L_{RTJ} (Face to Face)	900LB	mm	216	229	254	279	305	371
	1500LB	mm	216	229	254	279	305	371
H(Open Height)	900 ~ 1500LB	mm	170	206	230	246	283	330
ϕW (Handwheel)		mm	100	125	160	160	180	220

Weight:150~1500LB Flange End, Standard port, Bolted Bonnet

CLASS	SIZE	15(1/2)	20(3/4)	25(1)	32(1 1/4)	40(1 1/2)	50(2)
	150LB	3.2	3.8	6.3	8.2	11.5	16.7
	300LB	3.6	4.5	7.1	9.3	13.2	18.8
	600LB	4.1	5.1	7.9	10.6	15.2	21.7
	900LB	7.2	9.4	14.2	17.5	24.7	38.1
	1500LB	7.2	9.4	14.2	17.5	24.7	38.1

The material is according to ASTM Standard
Model Denote:EFC=Elite Flow Control | 1/2=Size in inch | GE=Globe Valve | 1=150Lb