

MODEL NO.:EFC-1/2CK1
Size:3/8" ~ 2"(DN10 ~ DN50)

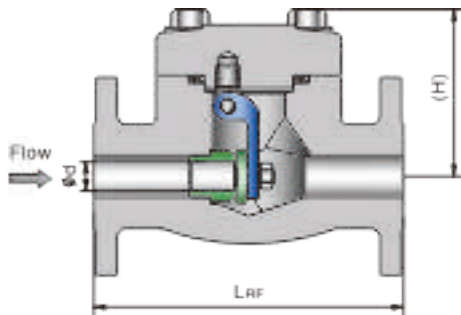

API 602 FORGED STEEL CHECK VALVE



SWING TYPE, FLANGED BOLTED BONNET
150 ~ 1500LB

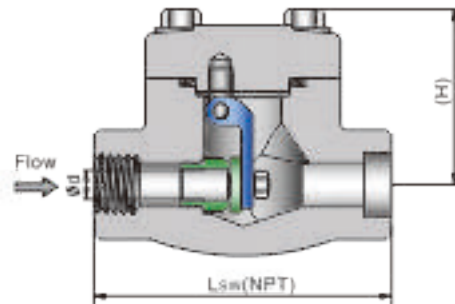

SWING TYPE, SW(NPT) BOLTED BONNET
800, 1500LB

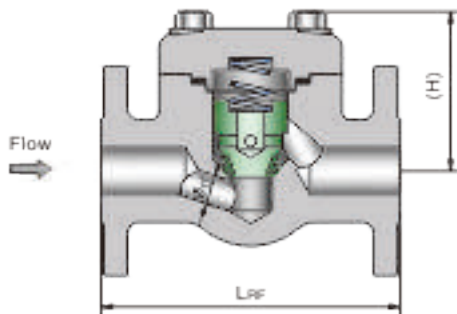

PISTON TYPE, FLANGED BOLTED BONNET
150 ~ 1500LB

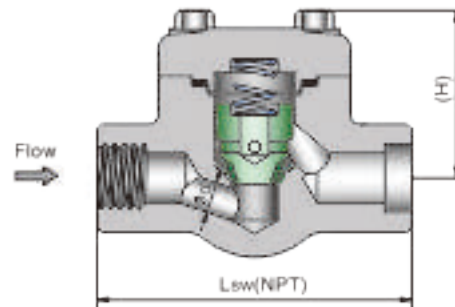

PISTON TYPE, SW(NPT) BOLTED BONNET
800, 1500LB

OPTIONAL DESIGN

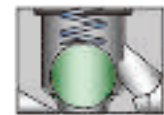

BALL TYPE

SPECIFICATION

Design & MFG.	API 602	End Threads	ASME B1.20.1
Press-Temp Rat.	ASME B16.34	Socket-Weld	ASME B16.11
End Flange	ASME B16.5	Test	API 598

Material List

PART	STANDARD MATERIALS					
BOOY	ASTM A105	ASTM A350LF2	ASTM A182 F304(L)	ASTM A182 F316(L)	ASTM A182 F51/F53	ASTM A182 F11/F22
SEAT	ASTM A182 F6a	ASTM A182 F6a	ASTM A182 F304(L)	ASTM A182 F316(L)	ASTM A182 F51/F53	ASTM A182 F11/F22
DISC	ASTM A182 F6a	ASTM A182 F6a	ASTM A182 F304(L)	ASTM A182 F316(L)	ASTM A182 F51/F53	ASTM A182 F11/F22
GASKET	SS+GRAPHITE					
BONNET	ASTM A105	ASTM A350 LF2	ASTM A182 F304(L)	ASTM A182 F316(L)	ASTM A182 F51/F53	ASTM A182 F11/F22
BOLT	ASTM A193 B7	ASTM A320 L7	ASTM A193 B8(M)	ASTM A193 B8(M)	ASTM A193 B8(M)	ASTM A193 B16
SPRING	SS304/SS316/17-7PH/INCONELx750					
HINGE	ASTM A182 F6a	ASTM A182 F6a	ASTM A182 F304(L)	ASTM A182 F316(L)	ASTM A182 F51/F53	ASTM A182 F304

The material is according to ASTM Standard

Model Denote:EFC=Elite Flow Control | 1/2=Size in inch | CK=CHECK Valve | 1=150Lb



MODEL NO.:EFC-1/2CK1
Size:3/8" ~ 2" (DN10 ~ DN50)

API 602 FORGED STEEL CHECK VALVE

SWING TYPE, 800LB SW(NPT), Bolted Bonnet

Nominal Diameter	Standard Port	mm(in)	15(1/2)	20(3/4)	25(1)	32(1 1/4)	40(1 1/2)	50(2)	65(2 1/2)
	Full Port	mm(in)	10(3/8)	15(1/2)	20(3/4)	25(1)	32(1 1/4)	40(1 1/2)	50(2)
ød (Flow Passway)		mm	10	13	18	23	28	36	44
Lsw(NPT)(Face to Face)		mm	79	92	111	120	120	140	178
H(Open Height)		mm	63	63	78	82	102	120	140
WEIGHT		kg	1.3	1.4	2.5	3.4	4.5	7.3	10

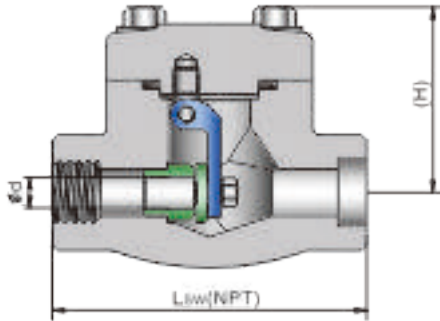

SWING TYPE, 1500LB SW(NPT), Bolted Bonnet

Nominal Diameter	Standard Port	mm(in)	15(1/2)	20(3/4)	25(1)	32(1 1/4)	40(1 1/2)	50(2)
	Full Port	mm(in)	10(3/8)	15(1/2)	20(3/4)	25(1)	32(1 1/4)	40(1 1/2)
ød (Flow Passway)		mm	10	13	18	23	28	36
Lsw(NPT)(Face to Face)		mm	92	111	120	120	140	178
H(Open Height)		mm	63	78	82	102	120	140
WEIGHT		kg	3.0	3.6	4.3	6.1	8.8	12.6

SWING TYPE, 150 ~ 600LB RF, Standard port, Bolted Bonnet

Nominal Diameter	mm(in)	15(1/2)	20(3/4)	25(1)	32(1 1/4)	40(1 1/2)	50(2)	
ød (Flow Passway)	mm	10	13	18	23	28	36	
L _{RF} (Face to Face)	150LB	mm	108	117	127	140	165	203
	300LB	mm	152	178	216	229	241	267
	600LB	mm	165	190	216	229	241	292
H(Open Height)	150 ~ 600LB	mm	63	63	78	82	102	120

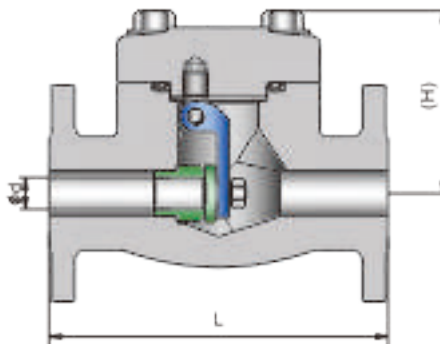

SWING TYPE CHECK VALVE

SWING TYPE, 900 ~ 1500LB RTJ, Standard port, Bolted Bonnet

Nominal Diameter	mm(in)	15(1/2)	20(3/4)	25(1)	32(1 1/4)	40(1 1/2)	50(2)	
ød (Flow Passway)	mm	10	13	18	23	28	36	
L _{RTJ} (Face to Face)	900LB	mm	216	229	254	279	305	371
	1500LB	mm	216	229	254	279	305	371
H(Open Height)	900 ~ 1500LB	mm	63	78	82	102	120	140

Weight: 150 ~ 1500LB Flange End, Standard port, Bolted Bonnet

CLASS	SIZE	15(1/2)	20(3/4)	25(1)	32(1 1/4)	40(1 1/2)	50(2)
150LB		2.3	2.6	4.5	5.9	7.9	12.8
300LB		2.5	3.6	5.3	7.3	10.2	13.7
600LB		3.3	3.9	6.1	8.4	11.4	16.5
900LB		5.1	9.2	12.2	15.1	21.2	25.4
1500LB		5.1	9.2	12.2	15.1	21.2	25.4

The material is according to ASTM Standard
 Model Denote: EFC=Elite Flow Control | 1/2=Size in inch | CK=CHECK Valve | 1=150Lb

MODEL NO.:EFC-1/2CK1
Size:3/8" ~ 2"(DN10 ~ DN50)



API 602 FORGED STEEL CHECK VALVE

PISTON TYPE,800LB SW(NPT),Bolted Bonnet

Nominal Diameter	Standard Port	mm(in)	15(1/2)	20(3/4)	25(1)	32(1 1/4)	40(1 1/2)	50(2)	65(2 1/2)
	Full Port	mm(in)	10(3/8)	15(1/2)	20(3/4)	25(1)	32(1 1/4)	40(1 1/2)	50(2)
∅d (Flow Passway)		mm	10	13	18	23	28	36	44
Lsw(NPT)(Face to Face)		mm	79	92	111	120	152	172	220
H(Open Height)		mm	63	63	78	82	102	120	140
WEIGHT		kg	1.2	1.4	2.6	3.9	5.6	8.9	12.5

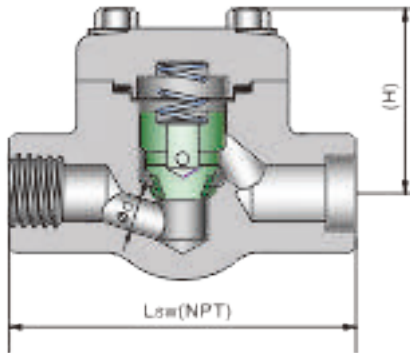

PISTON TYPE,1500LB SW(NPT),Bolted Bonnet

Nominal Diameter	Standard Port	mm(in)	15(1/2)	20(3/4)	25(1)	32(1 1/4)	40(1 1/2)	50(2)
	Full Port	mm(in)	10(3/8)	15(1/2)	20(3/4)	25(1)	32(1 1/4)	40(1 1/2)
∅d (Flow Passway)		mm	10	13	18	23	28	36
Lsw(NPT)(Face to Face)		mm	92	111	120	152	172	220
H(Open Height)		mm	63	78	82	102	120	140
WEIGHT		kg	3.0	3.4	4.8	6.5	10.1	14.6

PISTON TYPE,150 ~ 600LB RF,Standard port,Bolted Bonnet

Nominal Diameter		mm(in)	15(1/2)	20(3/4)	25(1)	32(1 1/4)	40(1 1/2)	50(2)
∅d (Flow Passway)		mm	10	13	18	23	28	36
LRF (Face to Face)	150LB	mm	108	117	127	140	165	203
	300LB	mm	152	178	203	216	229	267
	600LB	mm	165	190	216	229	241	292
H(Open Height)	150 ~ 600LB	mm	63	63	78	82	102	120

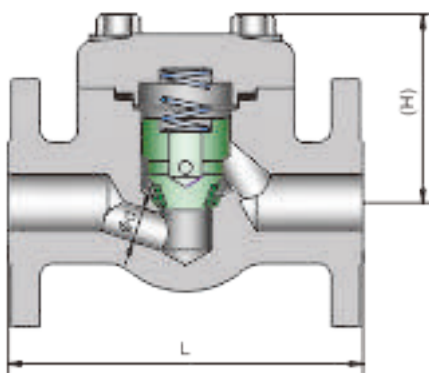

PISTON TYPE CHECK VALVE

PISTON TYPE,900 ~ 1500LB RTJ,Standard port,Bolted Bonnet

Nominal Diameter		mm(in)	15(1/2)	20(3/4)	25(1)	32(1 1/4)	40(1 1/2)	50(2)
∅d (Flow Passway)		mm	10	13	18	23	28	36
LRTJ (Face to Face)	900LB	mm	216	229	254	279	305	371
	1500LB	mm	216	229	254	279	305	371
H(Open Height)	900 ~ 1500LB	mm	63	78	82	102	120	140

Weight:150 ~ 1500LB Flange End,Standard port,Bolted Bonnet

CLASS	SIZE	15(1/2)	20(3/4)	25(1)	32(1 1/4)	40(1 1/2)	50(2)
	150LB	2.2	2.6	4.9	6.4	9.1	14.3
	300LB	2.4	3.6	5.7	7.9	11.3	15.2
	600LB	3.3	3.9	6.5	8.9	12.5	18.3
	900LB	5.1	8.9	13.1	1.5	22.5	27.5
	1500LB	5.1	8.9	13.1	1.5	22.5	27.5

The material is according to ASTM Standard
Model Denote:EFC=Elite Flow Control | 1/2=Size in inch | CK=CHECK Valve | 1=150Lb